



advanced.farm.
BetterPack.

Introducing the BetterPack™ autonomous fresh strawberry packline: a gentle, cost-effective approach to packing fresh strawberries to drive harvest headcount reduction on the ranch.



Bulk Harvest



Dispatched for Pre-Cooling

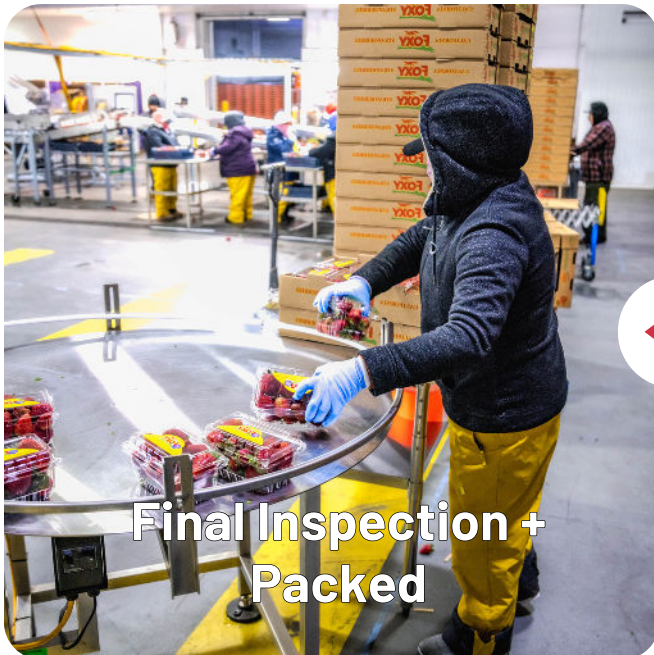

Final Inspection + Packed

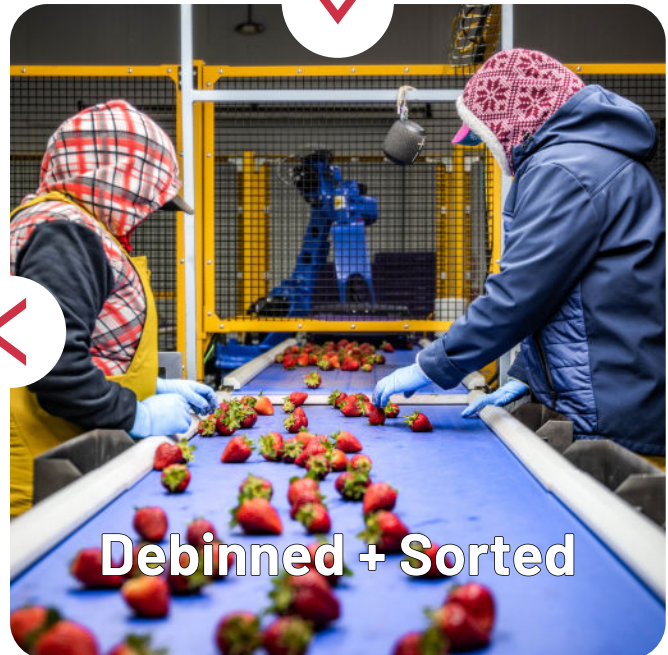

Debinned + Sorted



Scan to play video.

See our packline technology in action.

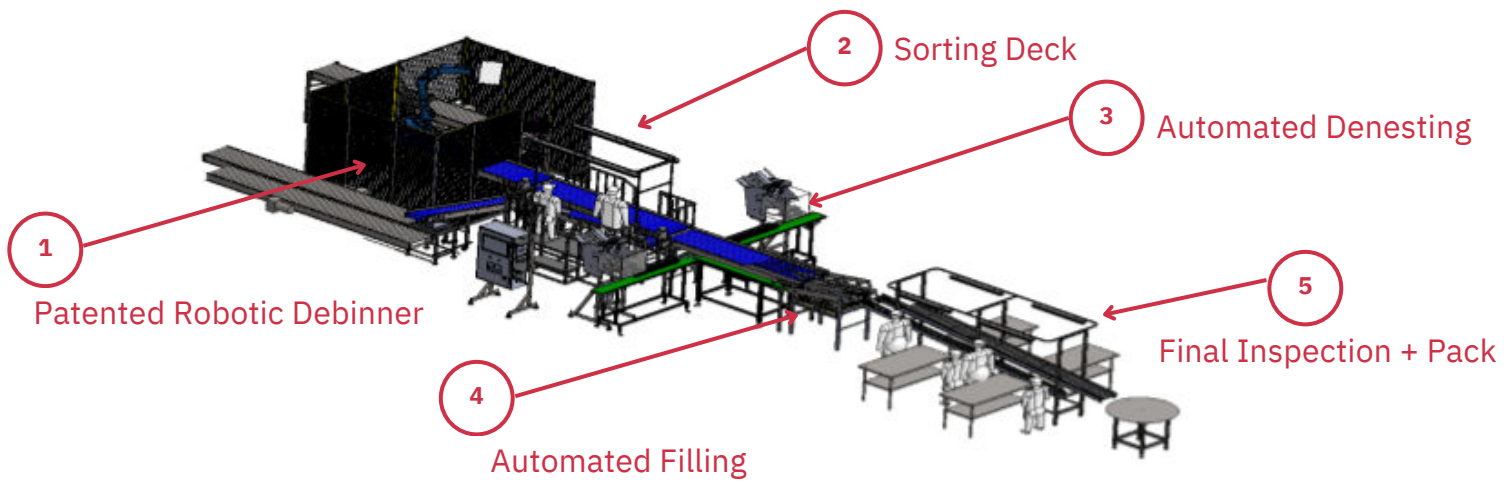

Product Specs

Input Rate	Up to 9,000 lbs/hr
Personnel Required	8 to 20
Ouput	Depends on fruit mix and packaging type
Footprint Required	80' x 25"
SKU's Supported	1lb, 2lb

Pricing Options

1 Line	\$850K
2 Lines	\$1.25M
Lease	Starting at \$100k/month

Module Integration Available:

- Check Weigher: **Reduce rejections due to weight**
- Top Sealers: **Explore innovative packaging opportunities**
- Decapper Integration: **Maximize secondary-grade**
- Data Package Upgrades: **Field and Fruit Data, Remote Monitoring**



advanced.farm.
BetterPack.



www.advanced.farm



info@advanced.farm



vimeo.com/advancedfarm



twitter.com/aftrobots



linkedin.com/company/advancedfarm/